

# LOTUS

 ALUTECH



<b>INDEX/PRODUCT CATEGORY</b>	<b>PAGE</b>
<b>Lotus Alutech</b>	<b>3</b>
<b>Service and Reliability</b>	<b>5</b>
<b>Quality and safety</b>	<b>7</b>
<b>Market fields applications</b>	<b>8</b>
<b>Optional and accessories</b>	<b>9</b>
<b>How to choose your ramp</b>	<b>10</b>
<b>01) Earth moving</b>	<b>12</b>
<b>02) Construction</b>	<b>13</b>
<b>03) Agriculture &amp; heavy-duty trailers</b>	<b>14</b>
<b>04) Light-duty Trailers</b>	<b>18</b>
<b>05) Hobbies / Gardening / Sport</b>	<b>20</b>
<b>06) Cleaning /Logistics / Events</b>	<b>21</b>
<b>07) Marine ramps</b>	<b>28</b>
<b>08) Wheelchair ramps</b>	<b>29</b>
<b>09) Special Ramps</b>	<b>30</b>
<b>10) Pedestrian Ramps</b>	<b>32</b>
<b>Industrial walkways and transit systems</b>	<b>35</b>
<b>Belloni Group</b>	<b>38</b>

# LOTUS ALUTECH

**Lotus Alutech** is an industrial company founded in 1980, highly specialized in processing **aluminum and its highest quality alloys**, market leader over Italy and EU since the beginning of '80s.

More in detail, Lotus Alutech is specialized in manufacturing aluminum **loading ramps** as well as **ALUMINUM, STEEL** and **STAINLESS-STEEL industrial transit system** (walkways, crossways, stairs).

Over the last 20 years Lotus Alutech has become one of the most relevant European manufacturers for both lines of product. Know-how, experience, professionalism, technical assistance are key points and a real added value within Lotus Alutech products, allowing the company to effectively and efficiently operate over EU and global markets.

Design and Quality are among the most important features, undoubtedly recognized by our key customers and partners around the world.

**Top level production** processes and **product certifications** have been implemented as an additional proof of Lotus Alutech product quality.

In particular bordered ramps can be supplied with **TÜV** certification and **WPQR** certificates all the welding process.

Lotus Alutech is part of Belloni Group, a larger **60-years-old** industrial group, composed by:

- **Belloni Lamiere:** Steel Service Center founded in 1958, **specialized in Plasma and Oxyfuel plates cutting** and Machining works.
- **Sideros Engineering:** founded in 1981 it is a Global leader in designing and manufacturing of **Extraction and Filtration products related to welding and cutting processes**. In particular, the product portfolio is composed of: Down Draft Tables and Automation for cutting machines, Dust Collectors for cutting and welding, Deburring Tumblers, Hydraulic straightening presses.
- **Sideros Machinery:** is the Automation spin-off of Sideros Engineering. Sideros Machinery is Global leader in designing and manufacturing **welding positioners, automated storage systems** (typically used for metal sheet, tubes and bars) and **load and unload system for metal sheets** to be integrated with Laser Cutting machines.





# SERVICE AND RELIABILITY



## **SAFETY**

Loading Capacity and technical features of all Lotus Alutech products are tested with the highest safety factors, either internally with our high level quality controls and through **certification companies**



## **CONTINUOUS QUALITY CHECKS**

the manufacturing process is traceable and carried out in compliance with the **highest quality standards**, through **quality checks** all over the production chain and using **certified raw material**



## **QUALITY**

**40 years of experience** in designing and manufacturing aluminum products resulted in the development of the strong collaboration with our suppliers, researching and selecting the **best Aluminum alloys and extrusions over the market**



## **FINISHING**

In addition to the highest quality standard, Lotus Alutech products are designed to be attractive with state of art welding and surface with **good looking finishing**



## **CERTIFIED WELDINGS**

**WPQR** certification (Welding Procedure Qualification Record) provides the assurance of **steady** and reliable welding joints, performed by our experienced certified welders



## **SUPPORT**

Lotus Alutech grants continuous **assistance and training** before and after the order; providing local language customer support in defining the right product and reaching the expected result



## **FLEXIBILITY**

Our Engineering department engineers and designs any kind of **customized solutions** according to the customer's requests, with continuous focus over **long lasting quality over the years**



## **TIMING**

**On time delivery** and fast shipping are always priorities



## **STRATEGIC LOCATION**

Lotus Alutech manufacturing plant is **strategically located** in the northern part of Italy: close to the major Italian and European highways and in proximity of most important ports and airport for intercontinental shipping



## **WIDESPREAD PRESENCE**

In addition to the attendance to major **international exhibitions** and events, Lotus Alutech distribution network ensures **local presence through sales partners all over the world**



# QUALITY AND SERVICE

**Lotus Alutech ramps** are manufactured with **6082 Aluminum Alloy**, designed and **certified** in order to simultaneously guarantee the highest quality, top safety standards and light weight for easier handling. Loading capacity range starts from a few hundred kilograms up to 22 Tons.

Most important and most widely recognized advantages of Lotus Alutech ramps are:



## **RANGE AND CUSTOMIZATION**

the **detailed engineering of every single aluminum profile** allows Lotus Alutech range of ramps to cover the widest application field and loading capacity needs, simultaneously allowing **stock optimization as models numerosity is reduced to the minimum.**



## **HIGH PERFORMANCE ALUMINUM ALLOYS**

**Less weight, more capacity:** balanced and optimized Aluminum profiles, along with the use of **top-resistance** and 100%-Italian production chain certified alloys grant certified performances.



## **EXPERIENCE AND SERVICE**

long lasting experience since 1980 enabled Lotus Alutech to develop the best long-time relationship with its customers and partners, which leads **customers to choose our products and solutions over time.**



## **FUNCTIONALITY MEETING AESTHETICS**

Passion toward handmade manufacturing meets performance and style. Detailed oriented manufacturing merge with the need of functionality and the pride of being the owner of an **excellent good-looking ramp**



## **PRODUCT INSURANCE**

above and beyond the **UE requirements**, Lotus Alutech customers can count on this additional plus and advantage



## **PROFESSIONAL PACKAGING**

Lotus Alutech ramps, being shipped worldwide, needs a proper and robust packaging for long distance shipping and warehouse stocking. Our operators use the same commitment to weld, to make a state-of-art packaging to allow a **quick** and efficient **stock and redistribution**

# MARKET FIELDS APPLICATIONS

Lotus Alutech ramps are used in multiple fields and applications:



**EARTH MOVING**



**CONSTRUCTION AND ROAD WORK**



**AGRICULTURE**



**TRANSPORT AND TRAILERS**



**GARDENING**



**HOBBY & SPORTS**



**CLEANING**



**LOGISTICS & EVENTS**



**MARINE RAMPS**



**WHEELCHAIR RAMPS**



**SPECIAL APPLICATIONS**



**PEDESTRIAN RAMPS AND WALKWAYS**

# OPTIONS AND ACCESSORIES

## SIDE BORDERS

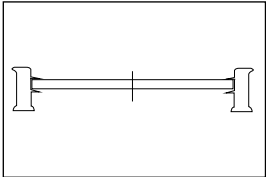

### WITH BORDERS "RC"

these ramps do offer the best **safety** against lateral slipping and tilting. Standard Models are **TUV certified**.

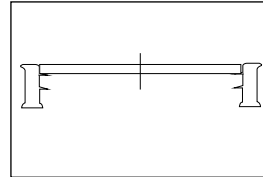

### WITHOUT BORDERS "RCS"

typically requested in case of **wide wheel or crawler equipped machines**. Possible to assemble the ramps together to make one unique floor.

## ANCHORING SYSTEMS

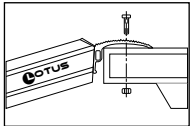

### STANDARD FIX: BOLT AND SCREWS

Screw to be dropped through the ramp lip (hole 15mm diameter is suggested) into the trailer/truck bed. Afterward fixed with bolt underneath.

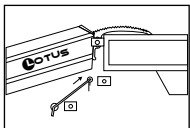

### FIX A: PIVOT AND CLAMP

Ramp is fixed through a removable pivot sliding into 2 clamps welded on trailer/truck platform (provided with removable pin)

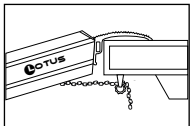

### FIX B: CHAIN WITH FIXING HOOK

A plate is welded on lower surface of ramp floor and fixed to the truck bed by a chain and hook (not supplied)

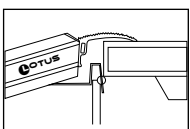

### FIX C: SECURITY CLAMP

Suitable for vehicle with banks, a clamp is welded on the ramp through a pivot pin, the fixing is operated by sliding the clamp into the vehicle bank. The clamp can shift almost all the bank length; even very versatile, it is not suggested for heavy loads.

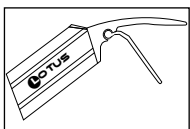

### FIX D: PLATE SYSTEM

The Anchoring is provided by the use of an aluminum pivoting plate. One side is "hinged" within ramp terminal, the other side to be slid between vehicle bank and bed. Available for 68 and 78 series models.

## CONNECTIONS

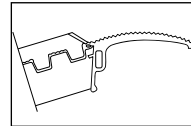

### STANDARD CONNECTION

elliptic shaped lip ensures an easier transit, in particular to small wheeled vehicles, along with better connection to truck bed.

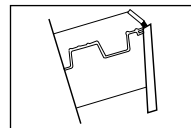

### A TYPE CONNECTION

steady and functional, must be used with specifically arranged truck beds Typically used on short ramps in order to reduce the connection size

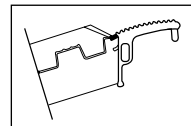

### B TYPE CONNECTION

semi-elliptical shaped terminal, with small tooth type plate welded on the bottom of the terminal. Used on specifically arranged trucks in order to reduce connection size

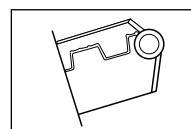

### BAR TYPE CONNECTION

typically used for heavy duty or very customized applications. Two plates are welded on truck loading bed, and a pivot pin (fixed upon the plates) is afterward the base slide for the terminal

## ACCESSORIES

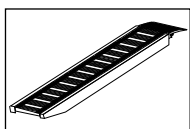

### RUBBER BANDS

If customer machine is equipped with **steel crawlers**, ramp floor must be protected through the **application of vulcanized rubber bands** (to be applied over a correspondent steel band). Time and deterioration resistant, this product is available for RCS ramps (without borders)



# HOW TO CHOOSE YOUR RAMP

In order to identify the right model according to your need, please check these five easy questions:

**1** WHAT LOADING HEIGHT DO I NEED TO REACH?  
 The definition of required Loading height  $H_c$  immediately identifies the right length  $L$  of the loading ramp from the values of the below table. **Once the length is correctly identified, you can check the required loading capacity**

**2** WHAT IS THE WEIGHT OF THE MACHINE TO BE LOADED?  
 It is critical to consider the maximum weight of the machine (Kg)  $P$  including operator(s), all liquids and accessories

**3** WHAT IS THE WHEELBASE OF THE MACHINE TO BE LOADED?  
 Measure the **distance between front and rear wheel** (wheeled machine) or **the ground length of the crawler** (crawled machine)  $I$  according to the picture

**4** RUBBER OR STEEL CRAWLER?  
**Rubber bands** are to be selected in case the machine is equipped with **steel crawlers**. Given that option, ramp model with loading capacity at **least 15% higher than the maximum weight** of the machine should be selected

**5** WHAT IS THE MAXIMUM WIDTH OF CRAWLERS/WHEELS?  
 In order to allow the best **weight distribution**, it is suggested **inner part** of the ramps to be maximum 100 mm **larger than the wheel/crawler**

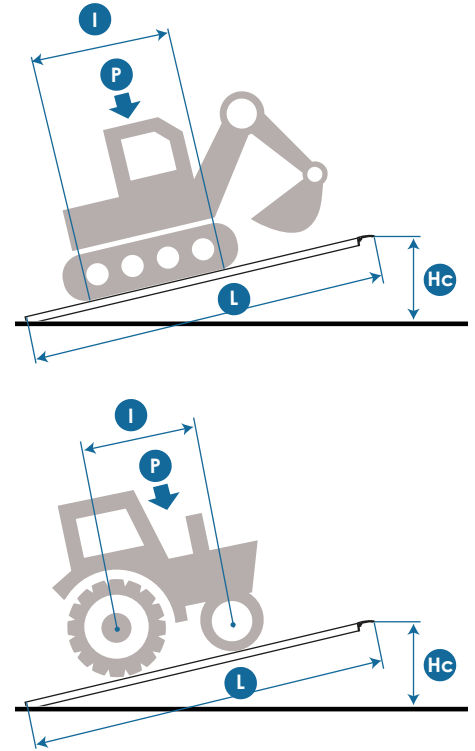

LOADING HEIGHT AND RAMP LENGTH CORRESPONDENCE								
Loading height (mm)	600	750	900	1050	1200	1350	1500	1650
Ramp Length (mm)	2000	2500	3000	3500	4000	4500	5000	5500

Ramp slope must not exceed 30% (equivalent to 16.5°)

It is possible to manufacture customized **ramp models with reduced slope** (typically a longer ramp): this request must be communicated while ordering, to customize the production of the ground terminal.





# HOW TO USE THIS CATALOGUE

- 1 CHOOSE YOUR CATEGORY OF USE
- 2 CHOOSE THE LENGTH CORRESPONDENT TO THE REQUIRED LOADING HEIGHT
- 3 IDENTIFY THE RAMP MODEL WITH MAXIMUM LOADING CAPACITY EQUAL TO OR HIGHER THAN THE OVERALL WEIGHT P (KG) OF YOUR MACHINE
- 4 CHECK IF STANDARD WIDTH OF THE RAMP IS COHERENT WITH MACHINE CRAWLER WIDTH
- 5 CHECK IF YOU NEED RAMP WITH BORDER (RC SERIES) OR WITHOUT BORDER (RCS SERIES)

If you need support or in case of specific request, please refer to Lotus Alutech Engineering Department

## Ramp Glossary

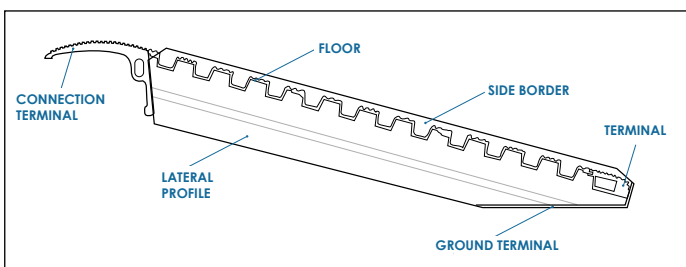

## Product Code

### RC 140/35 L

- “L” identifies if model is larger than standard
- “P” Thicker floor used on large RCS models
- Total length of the ramp (Ex: 35 = 3.500 mm)
- Lateral profile height (ex: 140 = 140 mm)
- Ramp with border (RC) or without border (RCS)

# 01 EARTH MOVING

Earth moving ramps are engineered in order to facilitate and speed up the loading and unloading operations involving **excavators, cranes and all wheeled and crawled earth moving equipments**. These ramps are particularly designed to meet needs of **strength and reliability** in all working conditions, able to reach a loading capacity up to 22.000 kgs (standard model). In order to provide the maximum flexibility of choice, these ramps are available model RC (with borders, **TUV certified**) and RCS (w/o borders). Within business sector and legal requirements, these ramps can be further customized on length, slope and width, along with **customized solutions** in order to meet higher loading capacity requirements.

In case of machine with **Steel crawlers, vulcanized rubber band** (over steel band reinforcement to ensure long lasting performance) are required in order to preserve the aluminum floor and available upon request. Furthermore, among the **several customization possibilities**, Lotus Alutech is able to manufacture **ramps with borders just on one (external) side** of the ramp, in line with our attitude to offer maximum customization flexibility.

With particular regard to the earth moving sector, where customization is often required, Lotus Alutech Commercial and Engineering Department are always ready for immediate assistance.

## ANCHORING

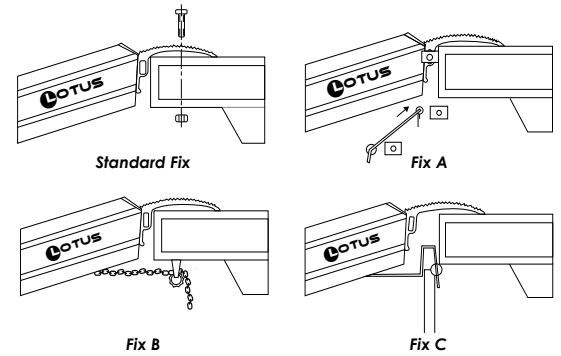

## CONNECTIONS

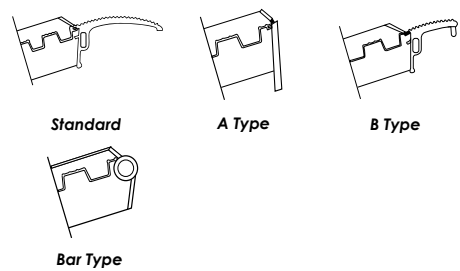

## RAMP MODELS

- Standard RC and RCS
- Special Ramps
- Single Border Ramp
- Rubber Bands



# 02 CONSTRUCTION

In this sector the continuous need to handle ramps and pedestrian walkways really find the perfect match with Lotus Alutech products, as they are engineered to find the optimal balance between **maximum loading capacity and reduced weight**. Available models:

- **Standard ramps** (RC/RCS model typically used for loading hydraulic lifters, platforms, pressure washers, generators, mixers, steamrollers etc.)
- Small/medium **pedestrian platforms** (RCF/RCFS used on construction sites)
- **Foldable ramps** (ZP/MP models), particularly useful for their easy-to-transport characteristics and compact dimensions

## ANCHORING SYSTEM

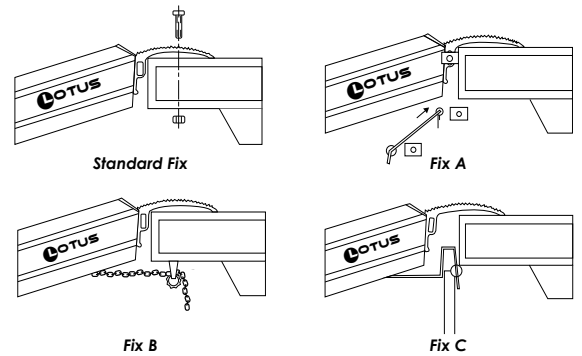

## RAMP MODELS

- Standard RC and RCS
- Special Ramps
- Single Border Ramp
- Rubber Bands

## CONNECTIONS

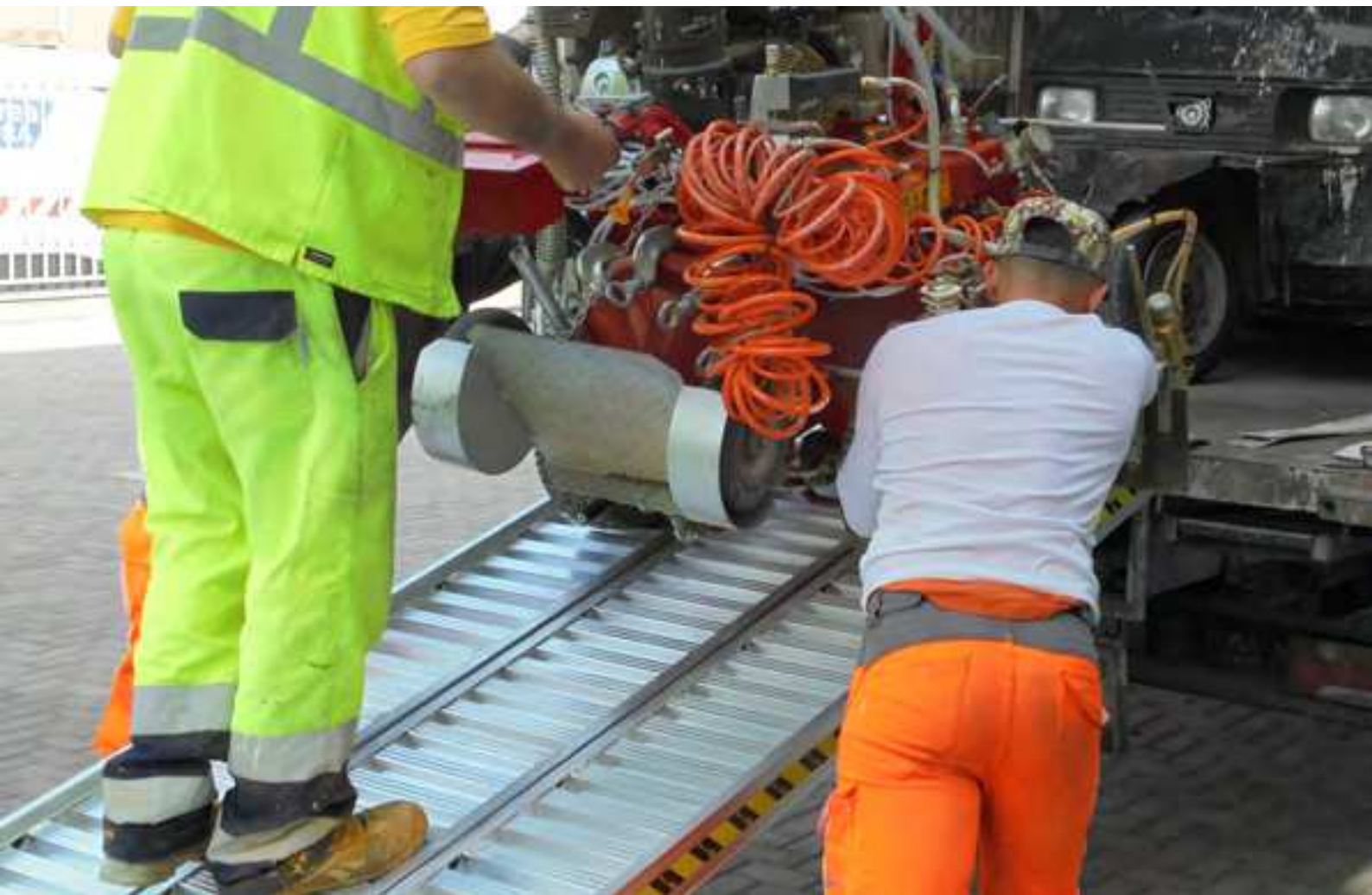
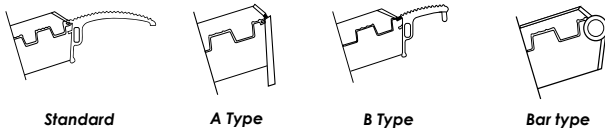

# 03 AGRICULTURE & HEAVY-DUTY TRAILER

Lotus Alutech Ramps best fit the needs of whom has to transport agricultural machineries, such as **tractors, grass packing/cultivator machineries, and heavy-duty trailers** in different locations. Different machines models and different weight distribution among front/back or left/right, requires highly **customized** loading capacities and balance to ensure use safety, which make most manufacturers and users to choose Lotus Alutech ramps as premium partner due to the wide range of models offered. In case of machine with **Steel crawler, vulcanized rubber bands** (over steel band) are required in order to preserve the aluminum floor and available upon request. Manufacturing ramps with borders just on one (external) side allows combining security with easy loading/unloading operation.

## ANCHORING

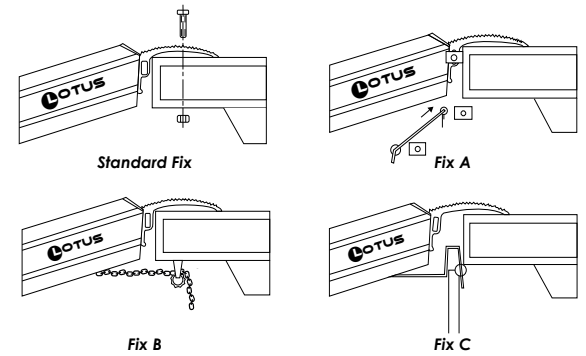

## CONNECTIONS

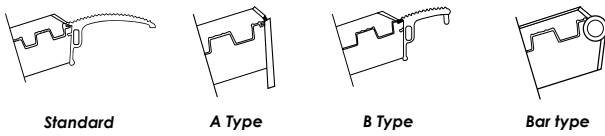

## RAMP MODELS

- Standard RC and RCS
- Special Ramps
- Single Border Ramp
- Rubber Bands



# RCS/RC MODELS

“Classical” loading Ramps are available both with border (RC) and without borders (RCS).  
Standard loading capacity is up to 22.000 kg

2000 mm RAMP LENGTH						600 mm LOADING HEIGHT					
Capacity per pair (Kg) over wheelbase (mm):			Size (mm)			Weight 1 ramp	Ramp Model			Rubber Band	
1.000 mm	1.500 mm	2.000 mm	Ext. Width	Int. width	Border Height	kg	W/O Border	With Border	Code	Code	
3.600	3.900	3.900	346	300	29	13	RCS	RC	95/20	GO 02	
5.200	5.500	5.500	382	320	29	17	RCS	RC	108/20	GO 02	
6.000	7.000	7.000	412	350	29	20	RCS	RC	122/20	GO 02	

RAMP LENGTH mm 2500						LOADING HEIGHT mm 750					
Capacity per pair (Kg) over wheelbase (mm):			Size (mm)			Weight 1 ramp	Ramp Model			Rubber Band	
1.000 mm	1.500 mm	2.000 mm	Ext. Width	Int. width	Border Height	kg	W/O Border	With Border	Code	Code	
2.560	3.350	3.500	346	300	29	16	RCS	RC	95/25	GO 02	
3.800	4.850	5.500	382	320	29	19	RCS	RC	108/25	GO 02	
5.500	7.000	7.000	412	350	29	25	RCS	RC	122/25	GO 02	
7.400	9.100	9.500	410	350	30	33	RCS	RC	140/25	GO 02	
7.400	9.100	9.500	460	400	30	35	RCS	RC	140/25L	GO 02	
10.300	13.200	14.000	466	400	30	41	RCS	RC	155/25	GO 02	
10.300	13.200	14.000	516	450	30	44	RCS	RC	155/25L	GO 02	
16.000	18.000	18.000	540	450	31	50	RCS	RC	175/25	GO 02	
16.000	18.000	18.000	590	500	31	56	-	RC	175/25L	-	
16.000	18.000	18.000	590	-	-	57	RCS	-	175/25P	GO 03	

3000 mm RAMP LENGTH						900 mm LOADING HEIGHT					
Capacity per pair (Kg) over wheelbase (mm):			Size (mm)			Weight 1 ramp	Ramp Model			Rubber Band	
1.000 mm	1.500 mm	2.000 mm	Ext. Width	Int. width	Border Height	kg	W/O Border	With Border	Code	Code	
1.970	2.430	2.900	346	300	29	19	RCS	RC	95/30	GO 02	
2.900	3.600	4.400	382	320	29	23	RCS	RC	108/30	GO 02	
4.250	5.100	6.500	412	350	29	29	RCS	RC	122/30	GO 02	
5.800	7.200	9.100	410	350	30	39	RCS	RC	140/30	GO 02	
5.800	7.200	9.100	460	400	30	41	RCS	RC	140/30L	GO 02	
8.300	10.300	13.000	466	400	30	48	RCS	RC	155/30	GO 02	
8.300	10.300	13.000	516	450	30	52	RCS	RC	155/30L	GO 02	
12.200	15.300	18.000	540	450	31	59	RCS	RC	175/30	GO 02	
12.200	15.300	18.000	590	500	31	65	-	RC	175/30L	-	
12.200	15.300	18.000	590	-	-	67	RCS	-	175/30P	GO 03	
17.000	20.000	22.000	620	500	40	82	-	RC	200/30	-	
17.000	19.000	19.000	670	550	40	86	-	RC	200/30L	-	

# RCS/RC MODELS

3500 mm RAMP LENGTH						1050 mm LOADING HEIGHT				
Capacity per pair (Kg) over wheelbase (mm):			Size (mm)			Weight 1 ramp	Ramp Model			Rubber Band
1.000 mm	1.500 mm	2.000 mm	Ext. Width	Int. width	Border Height	kg	W/O Border	With Border	Code	Code
1.600	1.900	2.200	346	300	29	22	RCS	RC	95/35	GO 02
2.350	2.800	3.300	382	320	29	27	RCS	RC	108/35	GO 02
3.400	4.000	4.900	412	350	29	33	RCS	RC	122/35	GO 02
4.770	5.720	6.780	410	350	30	40	RCS	RC	140/35	GO 02
4.770	5.720	6.780	460	400	30	42	RCS	RC	140/35L	GO 02
6.700	8.050	9.850	466	400	30	56	RCS	RC	155/35	GO 02
6.700	8.050	9.850	516	450	30	59	RCS	RC	155/35L	GO 02
10.000	11.850	14.400	540	450	31	69	RCS	RC	175/35	GO 02
10.000	11.850	14.400	590	500	31	75	-	RC	175/35L	-
10.000	11.850	14.400	590	-	-	78	RCS	-	175/35P	GO 03
13.500	16.500	20.000	620	500	40	95	-	RC	200/35	-
13.500	16.500	19.000	670	550	40	99	-	RC	200/35L	-

4000 mm RAMP LENGTH						1200 mm LOADING HEIGHT				
Capacity per pair (Kg) over wheelbase (mm):			Size (mm)			Weight 1 ramp	Ramp Model			Rubber Band
1.000 mm	1.500 mm	2.000 mm	Ext. Width	Int. width	Border Height	kg	W/O Border	With Border	Code	Code
1.340	1.550	1.750	346	300	29	25	RCS	RC	95/40	GO 02
1.950	2.300	2.650	382	320	29	30	RCS	RC	108/40	GO 02
2.800	3.200	3.800	412	350	29	37	RCS	RC	122/40	GO 02
3.970	4.600	5.400	410	350	30	42	RCS	RC	140/40	GO 02
3.970	4.600	5.400	460	400	30	44	RCS	RC	140/40L	GO 02
5.600	6.670	7.730	466	400	30	63	RCS	RC	155/40	GO 02
4.000	5.200	6.300	516	450	30	54	RCS	RC	155/40LD	GO 02
5.600	6.670	7.730	516	450	30	67	RCS	RC	155/40L	GO 02
8.400	9.800	11.400	540	450	31	78	RCS	RC	175/40	GO 02
8.400	9.800	11.400	590	500	31	85	-	RC	175/40L	-
8.400	9.800	11.400	590	-	-	88	RCS	-	175/40P	GO 03
11.000	13.000	15.800	620	500	40	108	-	RC	200/40	-
11.000	13.000	15.800	670	550	40	112	-	RC	200/40L	-

4500 mm RAMP LENGTH						1350 mm LOADING HEIGHT				
Capacity per pair (Kg) over wheelbase (mm):			Size (mm)			Weight 1 ramp	Ramp Model			Rubber Band
1.000 mm	1.500 mm	2.000 mm	Ext. Width	Int. width	Border Height	kg	W/O Border	With Border	Code	Code
1.700	1.900	2.150	382	320	29	34	RCS	RC	108/45	GO 02
2.400	2.750	3.200	412	350	29	41	RCS	RC	122/45	GO 02
3.400	3.930	4.450	410	350	30	47	RCS	RC	140/45	GO 02
3.400	3.930	4.450	460	400	30	50	RCS	RC	140/45L	GO 02
4.850	5.600	6.350	466	400	30	67	RCS	RC	155/45	GO 02
4.850	5.600	6.350	516	450	30	70	RCS	RC	155/45L	GO 02
7.200	8.250	9.400	540	450	31	87	RCS	RC	175/45	GO 02
7.200	8.250	9.400	590	500	31	95	-	RC	175/45L	-
7.200	8.250	9.400	590	-	-	99	RCS	-	175/45P	GO 03
10.000	11.000	13.000	620	500	40	121	-	RC	200/45	-
10.000	11.000	13.000	670	550	40	126	-	RC	200/45L	-

# RCS/RC MODELS

5000 mm RAMP LENGTH						1500 mm LOADING HEIGHT					
Capacity per pair (Kg) over wheelbase (mm):			Size (mm)			Weight 1 ramp	Ramp Model			Rubber Band	
1.000 mm	1.500 mm	2.000 mm	Ext. Width	Int. width	Border Height	kg	W/O Border	With Border	Code	Code	
2.970	3.400	3.820	410	350	30	52	RCS	RC	140/50	GO 02	
2.970	3.400	3.820	460	400	30	55	RCS	RC	140/50L	GO 02	
4.250	4.870	5.400	466	400	30	74	RCS	RC	155/50	GO 02	
4.250	4.870	5.400	516	450	30	78	RCS	RC	155/50L	GO 02	
6.350	7.100	8.000	540	450	31	96	RCS	RC	175/50	GO 02	
6.350	7.100	8.000	590	500	31	105	-	RC	175/50L	-	
6.350	7.100	8.000	590	-	-	109	RCS	-	175/50P	GO 03	
8.500	9.700	11.000	620	500	40	134	-	RC	200/50	-	
8.500	9.700	11.000	670	550	40	139	-	RC	200/50L	-	

5500 mm RAMP LENGTH						1650 mm LOADING HEIGHT					
Capacity per pair (Kg) over wheelbase (mm):			Size (mm)			Weight 1 ramp	Ramp Model			Rubber Band	
1.000 mm	1.500 mm	2.000 mm	Ext. Width	Int. width	Border Height	kg	W/O Border	With Border	Code	Code	
7.600	8.700	9.700	620	500	40	147	-	RC	200/55	-	
7.600	8.700	9.700	670	550	40	153	-	RC	200/55L	-	

Special "twin type" ramp, standard floor with additional aluminum sheet



# 04 LIGHT-DUTY TRAILERS

Over the years, Lotus Alutech has developed and grown its product range designing and manufacturing ramp models for the most varied applications, in particular for light-duty trailer industry (i.e. car trailers). Typical request of **customization** involves the height of lateral profile, in order to allow the possibility to slide the ramp under the trailer loading bed. Design and functionality make a perfect match with the top of the market reliability (highest safety ratios are third party tested and certified). Unique user experience and maximum durability are the goals of Lotus Alutech designers developing new products. Reseller and final users can rely on a **really wide range of models**, while trailer manufacturers can count on the professionalism and experience of Lotus Alutech Engineering Department from the prototyping phase to the final **large series on-time and precise production**. Further customization available for instance the application of Manufacturer's dedicated stickers.

## CONNECTIONS

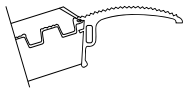

Standard

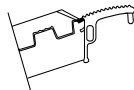

B Type

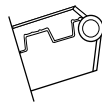

Bar type

## ANCHORING SYSTEM

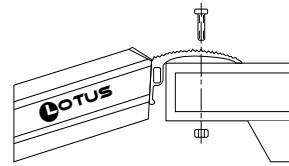

Standard Fix

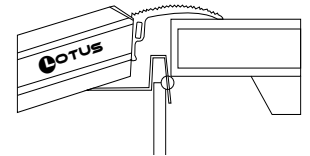

Fix C

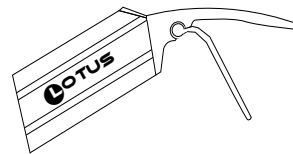

FIX D. PLATE SYSTEM

## RAMP MODELS

- Special Ramps RC and RCS
- Special Ramps



# RCS 68/78 MODELS

## 1500 mm RAMP LENGTH

## 450 mm LOADING HEIGHT

Capacity per pair (Kg) over wheelbase (mm):			Size (mm)	Weight 1 ramp	Ramp Model	
1.000 mm	1.500 mm	2.000 mm	Ext. Width	KG	W/O Border	Code
2.600	2.600	2.700	310	9	RCS	68/15
2.600	2.600	2.700	510	12	RCS	68/15L
3.500	3.500	3.600	310	10	RCS	78/15

## 2000 mm RAMP LENGTH

## 600 mm LOADING HEIGHT

Capacity per pair (Kg) over wheelbase (mm):			Size (mm)	Weight 1 ramp	Ramp Model	
1.000 mm	1.500 mm	2.000 mm	Ext. Width	KG	W/O Border	Code
2.500	2.500	2.500	310	12	RCS	68/20
2.500	2.500	2.500	510	15	RCS	68/20L
3.400	3.400	3.400	310	13	RCS	78/20

## 2500 mm RAMP LENGTH

## 750 mm LOADING HEIGHT

Capacity per pair (Kg) over wheelbase (mm):			Size (mm)	Weight 1 ramp	Ramp Model	
1.000 mm	1.500 mm	2.000 mm	Ext. Width	KG	W/O Border	Code
1.800	1.900	2.000	310	14	RCS	68/25
1.800	1.900	2.000	510	19	RCS	68/25L
2.400	2.550	2.700	310	15	RCS	78/25

## 3000 mm RAMP LENGTH

## 900 mm LOADING HEIGHT

Capacity per pair (Kg) over wheelbase (mm):			Size (mm)	Weight 1 ramp	Ramp Model	
1.000 mm	1.500 mm	2.000 mm	Ext. Width	KG	W/O Border	Code
1.400	1.500	1.600	310	17	RCS	68/30
1.400	1.500	1.600	510	22	RCS	68/30L
1.900	2.100	2.200	310	18	RCS	78/30

## 3500 mm RAMP LENGTH

## 1050 mm LOADING HEIGHT

Capacity per pair (Kg) over wheelbase (mm):			Size (mm)	Weight 1 ramp	Ramp Model	
1.000 mm	1.500 mm	2.000 mm	Ext. Width	KG	W/O Border	Code
1.150	1.250	1.300	310	19	RCS	68/35
1.150	1.250	1.300	510	25	RCS	68/35L
1.550	1.650	1.750	310	21	RCS	78/35

# 05 HOBBIES / GARDENING / SPORT

Motorbikes, lawnmowers, small tractors, quads and snowmobiles are just some of the machine whose transport can be highly eased though the use of Lotus Alutech ramps. **Foldable ramps** (MP and ZP models) and **foldable platforms** (RCFP and RCF-SP Models) allow the easy handling and loading / unloading operations of vehicles up to 1050 kg over small trailers. Folding platform are designed with certified **anti-slippery floor** and each model is available both with open or fully closed floor type.

## ANCHORING

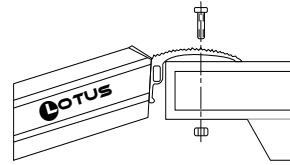

Standard Fix

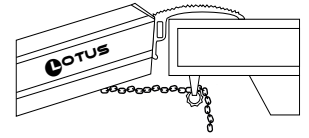

Fix C

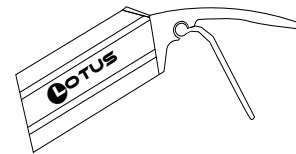

FIX D (PLATE SYSTEM)

## CONNECTIONS

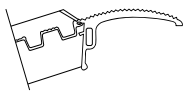

Standard

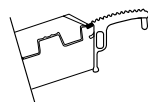

B Type

## RAMP MODELS

- Standard RC and RCS
- Special
- Single Border
- Foldable
- Single platform open/closed floor
- Foldable platform



# 06 CLEANING, LOGISTICS, EVENTS

The rising need of safety and portable products (like theater and music trolleys, speakers, music instruments and industrial washing machines) led Lotus Alutech to the industrialization of a dedicated line of ramps for that purpose. **Dedicated “thinner” profiles, along with special anti-slippery surfaces, allow to contain weight and dimensions.** Lotus Alutech Engineering Department is available to customize any kind of ramps depending on the purpose and the object to carry on (i.e. in case of extra-lowered flatbed).

## ANCHORING

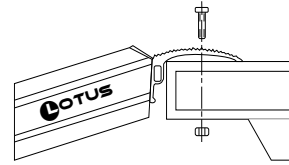

Standard Fix

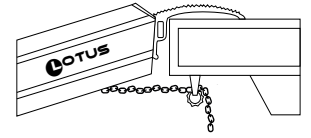

Fix B

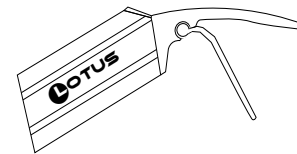

FIX D (PLATE SYSTEM)

## CONNECTIONS

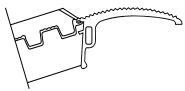

Standard

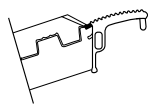

B Type

## RAMP MODELS

- Standard RC and RCS
- Special
- Single Border
- Foldable
- Single platform open/closed floor
- Foldable platform



# RCFS/RCF MODELS

## SINGLE LARGE RAMPS – CLOSED (C) OR OPEN (A) TYPE ANTI-SLIPPERY FLOOR

Such **platforms** are available with and without lateral security borders

2000 mm RAMP LENGTH								600 mm LOADING HEIGHT				
Load capacity (kg)				Size (mm)			Weight 1 ramp kg	Ramp Model		Floor		
Manual pallet truck		Trolleys		Ext. Width	Int. width	Border Height		W/O Border	With Border	Code	Closed	Open
(C)	(A)	(C)	(A)									
1.050	1.000	400	400	600	554	29	22	RCFS	RCF	95/20	C	A
1.000	1.000	800	650	600	538	29	24	RCFS	RCF	108/20	C	A
1.050	1.000	400	400	1.000	954	29	34	RCFS	RCF	95/20L	C	A
1.100	1.000	800	650	1.000	938	29	36	RCFS	RCF	108/20L	C	A

2500 mm RAMP LENGTH								750 mm LOADING HEIGHT				
Load capacity (kg)				Size (mm)			Weight 1 ramp kg	Ramp Model		Floor		
Manual pallet truck		Trolleys		Ext. Width	Int. width	Border Height		W/O Border	With Border	Code	Closed	Open
(C)	(A)	(C)	(A)									
950	950	400	400	600	554	29	28	RCFS	RCF	95/25	C	A
1.100	1.000	800	650	600	538	29	30	RCFS	RCF	108/25	C	A
950	950	400	400	1.000	954	29	41	RCFS	RCF	95/25L	C	A
1.100	1.000	800	650	1.000	938	29	43	RCFS	RCF	108/25L	C	A

3000 mm RAMP LENGTH								900 mm LOADING HEIGHT				
Load capacity (kg)				Size (mm)			Weight 1 ramp kg	Ramp Model		Floor		
Manual pallet truck		Trolleys		Ext. Width	Int. width	Border Height		W/O Border	With Border	Code	Closed	Open
(C)	(A)	(C)	(A)									
850	850	400	400	600	554	29	31	RCFS	RCF	95/30	C	A
1.100	1.000	800	650	600	538	29	35	RCFS	RCF	108/30	C	A
850	850	400	400	1.000	954	29	48	RCFS	RCF	95/30L	C	A
1.100	1.000	800	650	1.000	938	29	51	RCFS	RCF	108/30L	C	A

3500 mm RAMP LENGTH								1050 mm LOADING HEIGHT				
Load capacity (kg)				Size (mm)			Weight 1 ramp kg	Ramp Model		Floor		
Manual pallet truck		Trolleys		Ext. Width	Int. width	Border Height		W/O Border	With Border	Code	Closed	Open
(C)	(A)	(C)	(A)									
750	750	400	400	600	554	29	36	RCFS	RCF	95/35	C	A
1.100	1.000	800	650	600	538	29	40	RCFS	RCF	108/35	C	A
750	750	400	400	1.000	954	29	56	RCFS	RCF	95/35L	C	A
1.100	1.000	800	650	1.000	938	29	58	RCFS	RCF	108/35L	C	A

4000 mm RAMP LENGTH								1200 mm LOADING HEIGHT				
Load capacity (kg)				Size (mm)			Weight 1 ramp kg	Ramp Model		Floor		
Manual pallet truck		Trolleys		Ext. Width	Int. width	Border Height		W/O Border	With Border	Code	Closed	Open
(C)	(A)	(C)	(A)									
650	650	400	400	600	554	29	41	RCFS	RCF	95/40	C	A
1.100	900	800	650	600	538	29	45	RCFS	RCF	108/40	C	A
650	650	400	400	1.000	954	29	61	RCFS	RCF	95/40L	C	A
1.100	1.000	800	650	1.000	938	29	66	RCFS	RCF	108/40L	C	A



# RCFSP/RCFP MODELS

## SINGLE FOLDABLE LARGE RAMPS CLOSED (C) OR OPEN (A) TYPE ANTI-SLIPPERY FLOOR

These models of **platforms** are particularly useful in all cases where excessive length could result in transport or stocking concerns. Available both with and without lateral security borders.

2000 mm RAMP LENGTH						600 mm LOADING HEIGHT				
Load capacity (kg)		Size (mm)			Weight 1 ramp kg	Ramp Model				
Manual pallet truck	Trolleys	Ext. Width	Int. width	Border Height		W/O Border	With Border	Code	Floor Closed Open	
500	300	600	554	29	24	RCFSP	RCFP	95/20	C	A
700	500	600	538	29	26	RCFSP	RCFP	108/20	C	A
500	300	1.000	954	29	36	RCFSP	RCFP	95/20L	C	A
700	500	1.000	938	29	38	RCFSP	RCFP	108/20L	C	A

2500 mm RAMP LENGTH						750 mm LOADING HEIGHT				
Load capacity (kg)		Size (mm)			Weight 1 ramp kg	Ramp Model				
Manual pallet truck	Trolleys	Ext. Width	Int. width	Border Height		W/O Border	With Border	Code	Floor Closed Open	
500	300	600	554	29	30	RCFSP	RCFP	95/25	C	A
700	500	600	538	29	32	RCFSP	RCFP	108/25	C	A
500	300	1.000	954	29	43	RCFSP	RCFP	95/25L	C	A
700	500	1.000	938	29	45	RCFSP	RCFP	108/25L	C	A

3000 mm RAMP LENGTH						900 mm LOADING HEIGHT				
Load capacity (kg)		Size (mm)			Weight 1 ramp kg	Ramp Model				
Manual pallet truck	Trolleys	Ext. Width	Int. width	Border Height		W/O Border	With Border	Code	Floor Closed Open	
500	300	600	554	29	33	RCFSP	RCFP	95/30	C	A
700	500	600	538	29	37	RCFSP	RCFP	108/30	C	A
500	300	1.000	954	29	50	RCFSP	RCFP	95/30L	C	A
700	500	1.000	938	29	53	RCFSP	RCFP	108/30L	C	A

3500 mm RAMP LENGTH						1050 mm LOADING HEIGHT				
Load capacity (kg)		Size (mm)			Weight 1 ramp kg	Ramp Model				
Manual pallet truck	Trolleys	Ext. Width	Int. width	Border Height		W/O Border	With Border	Code	Floor Closed Open	
500	300	600	554	29	38	RCFSP	RCFP	95/35	C	A
700	500	600	538	29	42	RCFSP	RCFP	108/35	C	A
500	300	1.000	954	29	58	RCFSP	RCFP	95/35L	C	A
700	500	1.000	938	29	60	RCFSP	RCFP	108/35L	C	A

4000 mm RAMP LENGTH mm 4000						1200 mm LOADING HEIGHT				
Load capacity (kg)		Size (mm)			Weight 1 ramp kg	Ramp Model				
Manual pallet truck	Trolleys	Ext. Width	Int. width	Border Height		W/O Border	With Border	Code	Floor Closed Open	
500	300	600	554	29	43	RCFSP	RCFP	95/40	C	A
700	500	600	538	29	47	RCFSP	RCFP	108/40	C	A
500	300	1.000	954	29	63	RCFSP	RCFP	95/40L	C	A
700	500	1.000	938	29	68	RCFSP	RCFP	108/40L	C	A



# RCS 68/78 MODELS

## 1500 mm RAMP LENGTH

## 450 mm LOADING HEIGHT

Capacity per pair (Kg) over wheelbase (mm):			Size (mm)	Weight 1 ramp	Ramp Model	
1.000 mm	1.500 mm	2.000 mm	Ext. Width	KG	W/O Border	Code
2.600	2.600	2.700	310	9	RCS	68/15
2.600	2.600	2.700	510	12	RCS	68/15L
3.500	3.500	3.600	310	10	RCS	78/15

## 2000 mm RAMP LENGTH

## 600 mm LOADING HEIGHT

Capacity per pair (Kg) over wheelbase (mm):			Size (mm)	Weight 1 ramp	Ramp Model	
1.000 mm	1.500 mm	2.000 mm	Ext. Width	KG	W/O Border	Code
2.500	2.500	2.500	310	12	RCS	68/20
2.500	2.500	2.500	510	15	RCS	68/20L
3.400	3.400	3.400	310	13	RCS	78/20

## 2500 mm RAMP LENGTH

## 750 mm LOADING HEIGHT

Capacity per pair (Kg) over wheelbase (mm):			Size (mm)	Weight 1 ramp	Ramp Model	
1.000 mm	1.500 mm	2.000 mm	Ext. Width	KG	W/O Border	Code
1.800	1.900	2.000	310	14	RCS	68/25
1.800	1.900	2.000	510	19	RCS	68/25L
2.400	2.550	2.700	310	15	RCS	78/25

## 3000 mm RAMP LENGTH

## 900 mm LOADING HEIGHT

Capacity per pair (Kg) over wheelbase (mm):			Size (mm)	Weight 1 ramp	Ramp Model	
1.000 mm	1.500 mm	2.000 mm	Ext. Width	KG	W/O Border	Code
1.400	1.500	1.600	310	17	RCS	68/30
1.400	1.500	1.600	510	22	RCS	68/30L
1.900	2.100	2.200	310	18	RCS	78/30

## 3500 mm RAMP LENGTH

## 1050 mm LOADING HEIGHT

Capacity per pair (Kg) over wheelbase (mm):			Size (mm)	Weight 1 ramp	Ramp Model	
1.000 mm	1.500 mm	2.000 mm	Ext. Width	KG	W/O Border	Code
1.150	1.250	1.300	310	19	RCS	68/35
1.150	1.250	1.300	510	25	RCS	68/35L
1.550	1.650	1.750	310	21	RCS	78/35

# MP/ZP Models

Available without borders only, these **FOLDABLE ramps** are particularly suitable for all those cases where transport or stocking concerns may arise due to ramp length.

## STANDARD FLOOR, W/O BORDER - FOLDABLE

Total length mm	Loading height mm	Capacity per pair (Kg) over wheelbase (mm):			Width mm	Weight 1 ramp Kg	Ramp Model	
		700 mm	1.250 mm	1.500 mm			W/O Borde	Code
1.500	450	1.050	1.050	1.050	200	7	RCS	<b>68/15MP</b> <b>68/15ZP</b>
					250	8		
2.000	600	1.000	1.000	1.000	200	9	RCS	<b>68/20MP</b> <b>68/20ZP</b>
					250	10		
2.500	750	700	700	700	200	11	RCS	<b>68/25MP</b> <b>68/25ZP</b>
					250	13		
3.000	900	550	550	550	200	13	RCS	<b>68/30MP</b> <b>68/30ZP</b>
					250	16		
3.500	1.050	450	450	450	200	15	RCS	<b>68/35MP</b> <b>68/35ZP</b>
					250	18		
4.000	1.200	400	400	400	200	17	RCS	<b>68/40MP</b> <b>68/40ZP</b>
					250	20		

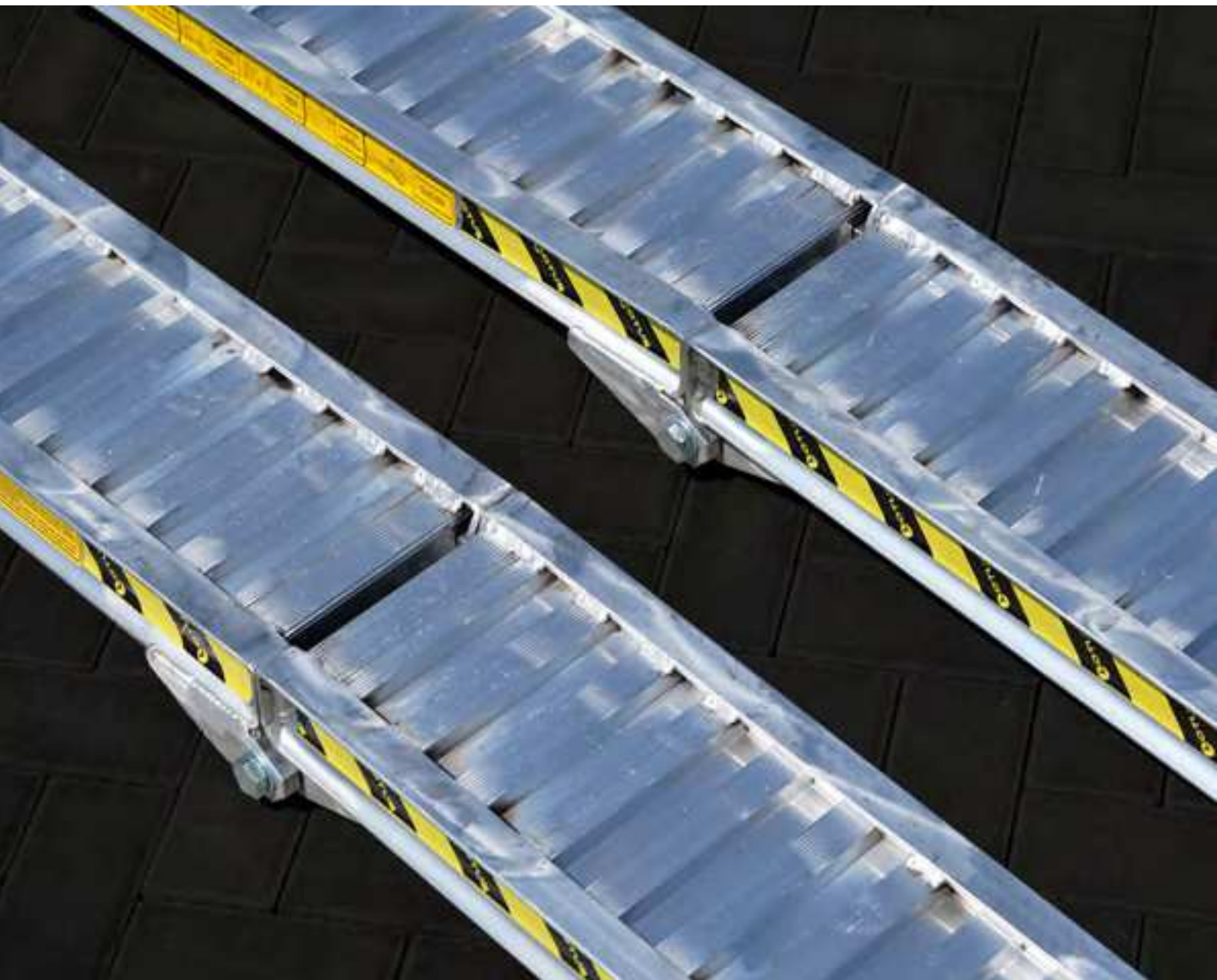

# 07 MARINE RAMPS

Lotus Alutech marine ramps product line is designed and engineered to be **light** (easier boarding) and **reliable**. In order to provide a state-of-the-art **protection over corrosive environments and cleaning agents**, a dedicated surface treatment (anodization) both in 10/15 and 20/25 Micron thickness is available. Removable and foldable (inner side) handrail (option particularly appreciated to optimize stocking space requirements) can be supplied upon request.

Aluminum Platforms are available within the range of marine ramps as well. They are mainly utilized within **harbor and docks** environment; customizable in width, length and docking points in order to effectively match maritime specific requirements. **Quality** of raw materials, aesthetics and easiness of usage over multiple scenarios, make Lotus Alutech ramps suitable to most of fluvial and marine applications.



# 08 WHEELCHAIR RAMPS

Since 1980, Lotus Alutech has been offering its know-how and experience towards people with reduced mobility needs: wheelchair ramps designing and manufacturing **complies the strictest Italian and EU related regulations**. Lotus Alutech **anti-slippery floor is certified** by an external third-party institute (Istituto Giordano). The extruded floor, entirely welded to the ramp structure, allows the ramp to completely avoid rust or deterioration risks almost in all weather conditions. Particular attention is always paid to **aesthetics** and the care to the design details (i.e. using anodization surface treatment), which allows the ramp to be installed even in the most elegant building, offices and mansions. Length, slope, platform size and the access areas are just some of the features that can be customized. Design and manufacturing are directly performed by Lotus Alutech Engineering Department, according to the building project manager requirements.



# 09 SPECIAL RAMPS

Beside the wide range of standard models, Lotus Alutech designs and manufactures a variety of **customizable solutions**: thinner hedges, thicker floor, higher loading capacity through the use of additional profiles, beside increasing or decreasing standard length/width. These modifications typically facilitate and decrease time during loading operations for special vehicles in particular. The use of aluminum ramps also results in avoiding investment in expensive lifting equipment (hydraulic lift/platforms, cranes) leading to minor capital investments and providing you with a good-looking working tool at the same time.



**Ramps for Car Hauler Trailers**

## **Ramps for Car Hauler Trailers**

They are tailored engineered to increase the trailer loading capacity by decreasing the vehicle weight (compared to standard steel ones).

## **KR900 maintenance ramps**

They are particularly used for maintenance needs to be performed on cars and caravans, allowing an easy access to the lower part of the vehicles without using expensive hydraulic lifters or maintenance graves.



**KR900 maintenance ramps**

## **Container Ramps**

These series of small ramps are particularly useful in order to preserve forklift integrity avoiding steps while performing containers loading operations.



**Container Ramps**

## **Curve shaped ramps**

These ramps are typically used in order to overcome small steps (up to 20 cm). The curved shape allows the loading/unloading operations with vehicles like lawnmowers and light cultivators in all those applications, where standard ramps cannot be used (i.e. due to reduced distance between machine bottom and soil).

## **Super-light Ramps:**

They are characterized by a slats style floor to avoid the deposit of stones and earth. No men-on-board use only.



**Super-light Ramps**



**Curve shaped ramps**

### Trailer Tilting Special Ramps

Thanks to the modularity construction of Lotus Alutech ramps for trailers, many customized configurations are available upon request. The main advantage of this type of ramp is the tare reduction, allowing a higher load capacity on the trailers. Given the long-term experience, our Engineering Department is available to assess any kind of custom requests.



### Triple Ramps

These ramps are the perfect combination between lightness and high loading capacity of ramps usually made in steel. **Trailers** can consequently increase **loading capacity** and lower weight with ramps easier to handle.

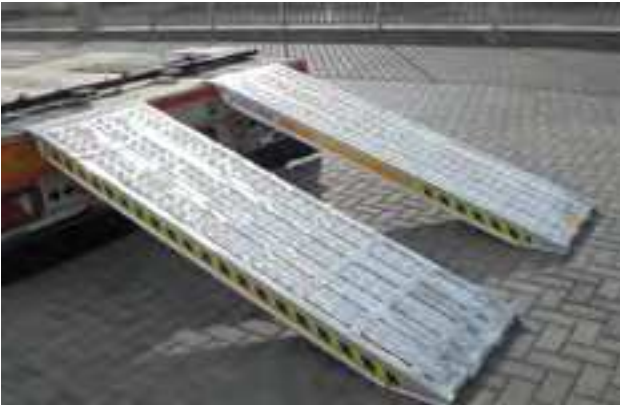

### Ramps with feet supporting Extra Load

They are typically used for loading/unloading operations of **heavy weight vehicles**. They are designed with lower slopes for easy transit, with **lengths up to 11 mt.**



**Reinforced ramp, guaranteeing a steady loading capacity for heavy duty vehicles**



# 10 PEDESTRIAN RAMPS

**Lightness, easiness to carry and handle** are among the distinctive characteristics of these pedestrian ramps.

Customizable in length and width, they are specifically engineered for **civil and road construction** work environment, typically used for overcoming trenches and ditches in total safety.

Available with **removable handrails** (possibility to further decrease the total weight of the platform) or with foldable handrails (extremely easy to handle and position on site).

## WITH REMOVABLE HANDRAILS

500 KG MAX. LOAD CAPACITY

MODEL	SIZE (mm) Width x Length	WEIGHT (kg)
LP-1000-60-AS LP-1000-100-AS	600 X 1000 1000 X 1000	26 31
LP-1250-60-AS LP-1250-100-AS	600 X 1250 1000 X 1250	31 37
LP-1500-60-AS LP-1500-100-AS	600 X 1500 1000 X 1500	36 43
LP-1750-60-AS LP-1750-100-AS	600 X 1750 1000 X 1750	41 49
LP-2000-60-AS LP-2000-100-AS	600 X 2000 1000 X 2000	45 55
LP-2250-60-AS LP-2250-100-AS	600 X 2250 1000 X 2250	50 61
LP-2500-60-AS LP-2500-100-AS	600 X 2500 1000 X 2500	55 67
LP-2750-60-AS LP-2750-100-AS	600 X 2750 1000 X 2750	60 73
LP-3000-60-AS LP-3000-100-PS	600 X 3000 1000 X 3000	65 80



Foldable handrails are available upon pedestrian ramps with minimum width 1000 mm. **Pedestrian Ramps length must be sized according to overall trench size:** minimum 30 cm per side must lay on ground level. Customized dimensions, different from the standard models listed in the table, can be manufactured upon request.

WITH FOLDABLE HANDRAILS		
500 KG MAX. LOAD CAPACITY		
MODEL	SIZE (mm) Width x Length	WEIGHT (kg)
LP-1000-100-PI	1000 X 1000	31
LP-1250-100-PI	1000 X 1250	37
LP-1500-100-PI	1000 X 1500	43
LP-1750-100-PI	1000 X 1750	49
LP-2000-100-PI	1000 X 2000	55
LP-2250-100-PI	1000 X 2250	61
LP-2500-100-PI	1000 X 2500	67
LP-2750-100-PI	1000 X 2750	73
LP-3000-100-PI	1000 X 3000	80





# INDUSTRIAL TRANSIT SYSTEMS

Beside Aluminum ramps, Lotus Alutech designs, manufactures and installs high quality industrial gangways, walkways, stairways and platforms. They are typically manufactured in:

- **6060 T6 Aluminum Alloy** (anodization surface treatment possibility)
- **304-316 Stainless Steel** (pickling or frosting surface treatments available)
- **Carbon Steel** (Painted or zinced surface treatments

are available)

Lotus Alutech industrial walkway systems are designed to **facilitate machine access** during manufacturing and maintenance operations. **Safety**, **solidity**, **quality** and **Exterior Design** are the main features making Lotus Alutech a point of reference on the market.

## STRENGTHS

- Light and robust products
- Modularity, easy and quick installation
- Tailored engineering
- Reliable and guaranteed delivery times
- EN ISO 14122 and OSHA complied
- Preliminary project technical assistance
- Quality and design since 1980
- 100% Italian Aluminum alloys and materials supply chain
- Unique punch-mark of each component
- Certified welding

## WHY ALUMINUM

Anodized aluminum total cost over walkway lifespan is not only lower than the one made in carbon steel, but user can also count upon an undoubtedly superior aesthetic perception and a minor corrosion against water, humidity, cleaning and other agents.

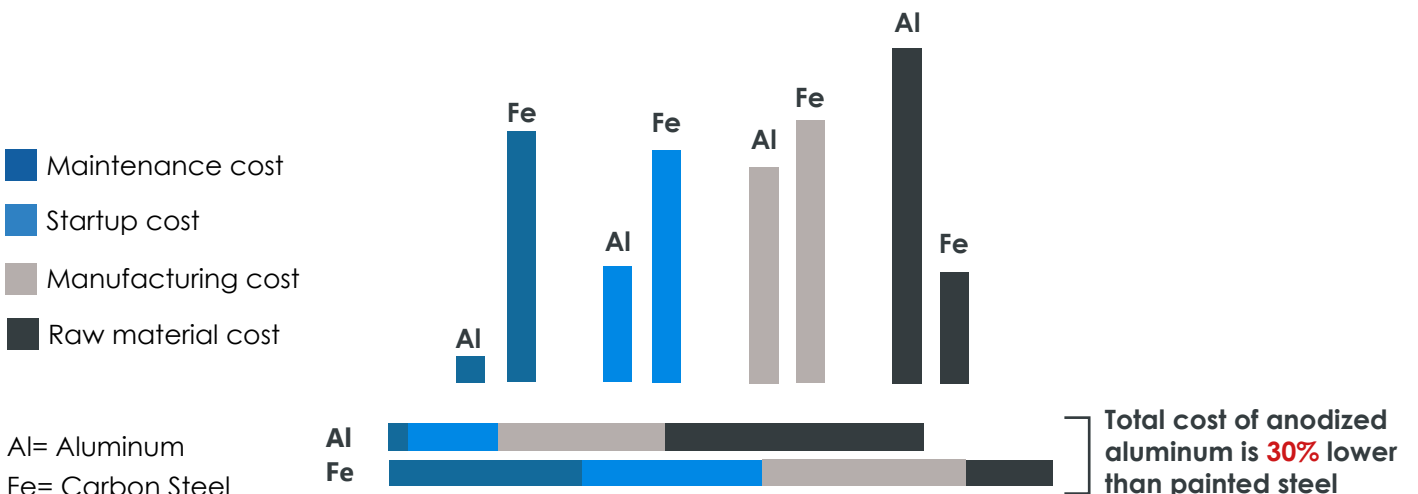



# BUSINESS SECTORS

Lotus Alutech industrial transit systems are typically chosen by the **OEM (machine manufacturers)** and **final users** willing to enhance and improve functionality of existing machineries, in particular **paper mills**.

Among the most usual Business sectors, Lotus Alutech has been designing and manufacturing transit systems in the following fields:

- **Paper machine manufactures**
- **Railway maintenance**
- **Aerospace OEM**
- **Oil and Gas**
- **Marine**
- **Shipbuilding OEM**
- **Food Industry machines and lines**
- **Water treatment & waste disposal**
- **Machine tools OEM**
- **Chemical plants**

## MAIN FEATURES

- Easier and quicker machine access
- Shorter maintenance time
- Operator safety improvement
- Machine design improvement



## HOW WE WORK



2D and **3D CAD simulation** enable Lotus Alutech Engineering Department to provide highly **customized solutions**, from an aesthetical and structural point of view



Each project is carried out meeting all **security requirements**, according to the highest **European and North American OSHA regulations**



**Pre and after sales assistance** are continuously guaranteed by Lotus Alutech technical and sales departments. Design and engineering of **transit systems** are conceived to improve the assembly procedures, time, and the overall production efficiency.



The Customization of the project **and the variety of the materials** processed (in particular: Aluminum alloys, Stainless steel and Carbon steel), make **Lotus Alutech** the right **Engineering and Fabrication one stop-shop partner**.

# BELLONI GROUP

Lotus Alutech is part of a major Italian industrial Group which includes: Sideros Engineering, Sideros Machinery and Belloni Lamiera.



**SIDEROS ENGINEERING** has been operating for over 40 years worldwide in the field of machinery for plate fabrication, in particular cutting and welding. It owes its success particularly to the high quality of its own products and to its constant commitment to R&D, innovation and industrialization of new products. Founded in 1981, Sideros Engineering has developed an enviable competitive advantage: the possibility of testing all new prototypes and the new technologies for a period of at least one year at BELLONI LAMIERE, a steel service center and fabrication shop operating since 1958, belonging to the same Industrial Group;

this combination enables SIDEROS ENGINEERING to constantly monitor the machines installed, thus allowing the optimization of products before their launch on the market and their subsequent industrialization. It is important to emphasize that Sideros Engineering is the only company in the world able to propose a wide range of complementary equipment to welding and cutting machines.

[www.siderosengineering.com](http://www.siderosengineering.com)





**SIDEROS MACHINERY** is the new automation division of Sideros Engineering: born in 2019, aimed to give more importance and focus to automation applied to the Sideros Engineering products, in particular on cutting and welding applications (Sheet metal, tubes and bars storage system, load/unload systems, welding positioners).

Technology and innovation of our machines are now developed by a new and young division, which can take advantage of great experience and knowledge developed in over 40 years in Sideros Engineering.

[www.siderosengineering.com](http://www.siderosengineering.com)



**BELLONI LAMIERE**, founded by Vincenzo Belloni in 1958, has been among the first companies in Italy supplying high quality oxy-fuel cut and machined parts. Today, after over "half a century" is among the few companies in Italy that can be proud of such a long presence and experience in metal plates processing industry. The quality of the products supplied, the accuracy of inspections during the working processes, and the punctuality make BELLONI LAMIERE a reliable benchmark at the European level.

Over the years Belloni Lamiere has specialized more and more in the following processes:

- **Oxy-fuel cutting:** metal plates of several thicknesses are cut by high performance cutting machines
- **Straightening:** equipped with 3 Hydraulic Presses

with movable vertical rods, movable cylinders and rotating hammer. Other services:

- **Milling:** it is performed by a 12 mt CNC control milling machine
- **Sandblasting,** deburring, heat treatments and machining.

Today BELLONI LAMIERE has become the main Test and demo Center of Sideros Engineering. Every year, Sideros tests and develops dozens of new products and technologies directly on-site. This great experience has led Sideros to design and manufacture reliable and technological advanced products over the past 40 years.

[www.bellonilamiere.com](http://www.bellonilamiere.com)



## **LOTUS ALUTECH**

Via Pascoli, 6 - I Casoni - 29027 Podenzano - (PC)

Phone: +39 0523 524262

E-mail: [info@lotusalluminio.com](mailto:info@lotusalluminio.com)



[www.lotusalluminio.com](http://www.lotusalluminio.com)